

OFFICE COPY

A/02A1/061/2005

Planning Permit No. **APPROVED**
 SUBJECT TO THE CONDITIONS IN THIS OFFICE LETTER.
 No. 01/5774/2004 Date 21/01/2005
 FOR MEMBER SECRETARY
 CHENNAI METROPOLITAN
 DEVELOPMENT AUTHORITY
 CHENNAI - 600 008.

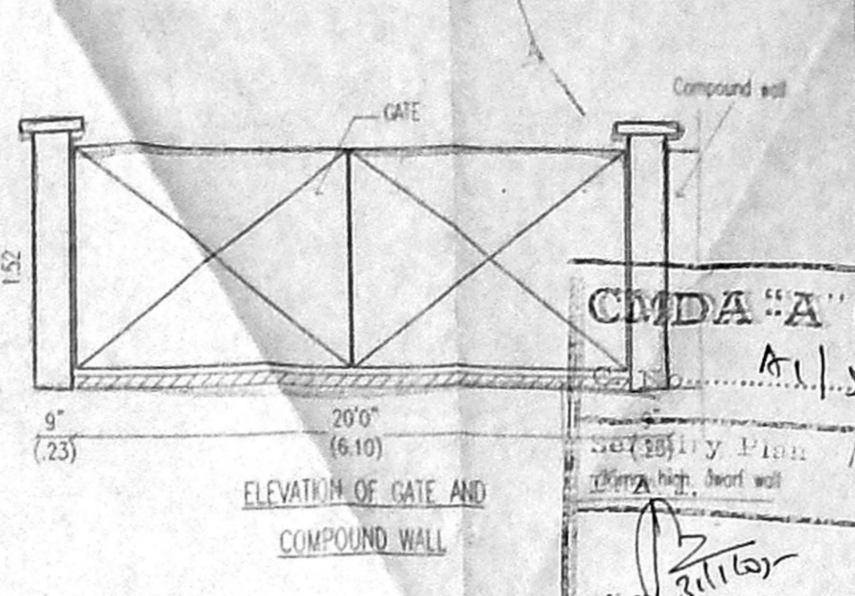
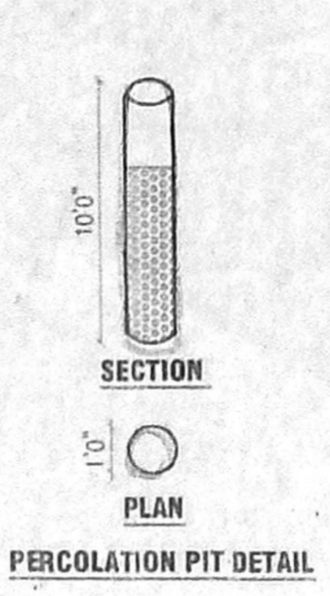
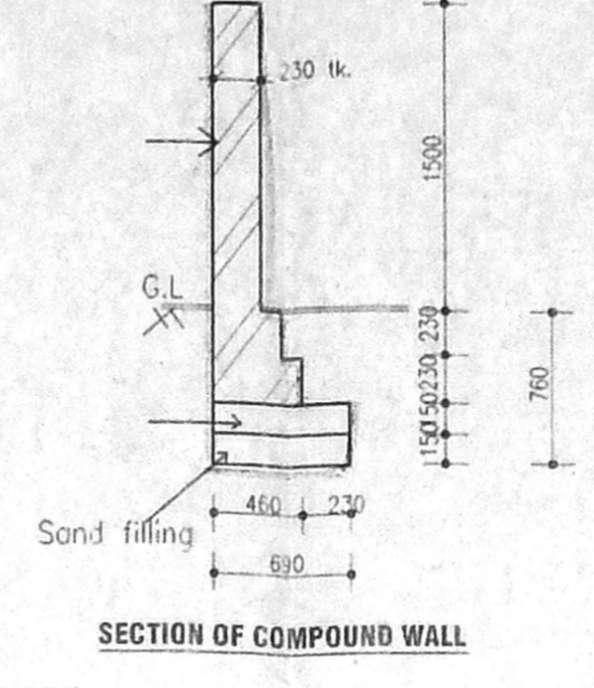
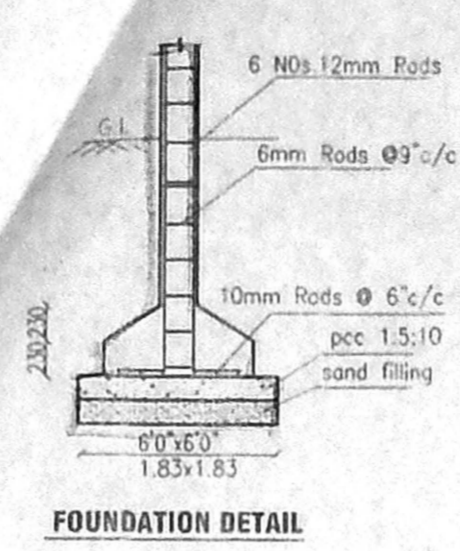
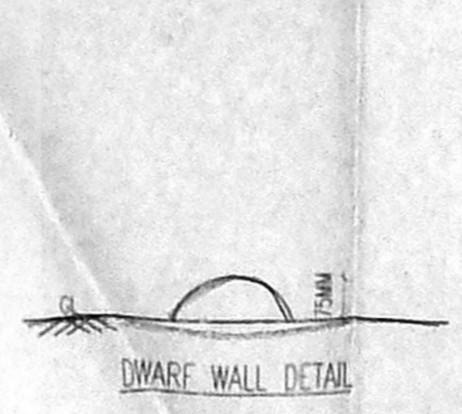
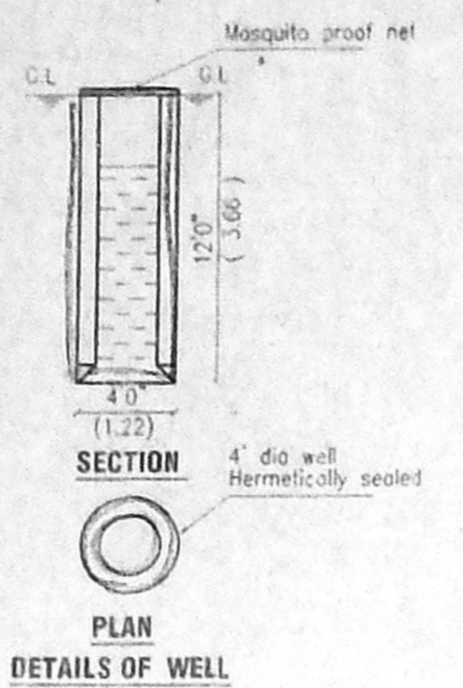
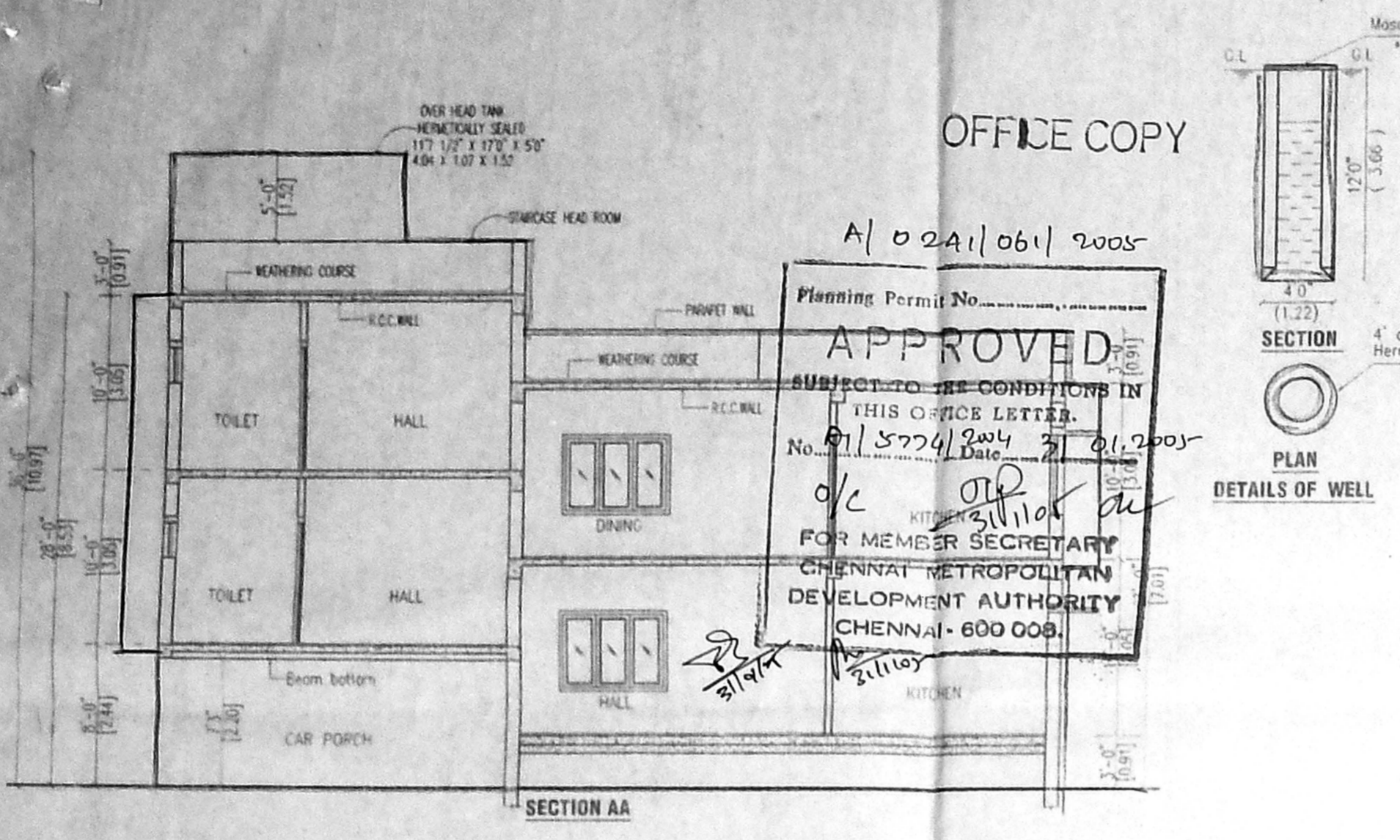

PLAN SHOWING THE PROPOSED RESIDENTIAL BUILDING AT PLOT NO.25,26 ,S.NO.299/2 OF DIVISION NO.137, VELACHERY VILLAGE CHENNAI

CMDA "A" CHENNAI
 A/02A1/061/2005
 SCHEDULE OF JOINERY

TYPE	DESCRIPTION	SIZE
MD	MAIN DOOR	4'0" X 7'0"
D	DOOR	3'6" X 7'0"
D1	DOOR	3'0" X 7'0"
D2	DOOR	2'6" X 7'0"
W26	WINDOW	2'6" X 4'6"
W3	WINDOW	3'0" X 4'6"
W4	WINDOW	4'0" X 4'6"
W5	WINDOW	6'0" X 4'6"
W6	WINDOW	8'0" X 4'6"
V	VENTILATOR	2'0" X 3'0"

AREA STATEMENT

S.NO.	DESCRIPTION	AREA (SQ. FT.)	AREA (SQ. M.)
1	PLOT EXTENT	5116.09	475.30
2	F.S.I ALLOWED	7674.13	712.95
3	GROUND FLOOR AREA	2054.08	190.83
4	FIRST FLOOR AREA	3277.69	304.50
5	SECOND FLOOR AREA (PART)	1364.70	126.78
6	TOTAL AREA	6696.47	622.12
7	F.S.I	1.30	
8	PLOT COVERAGE	64%	

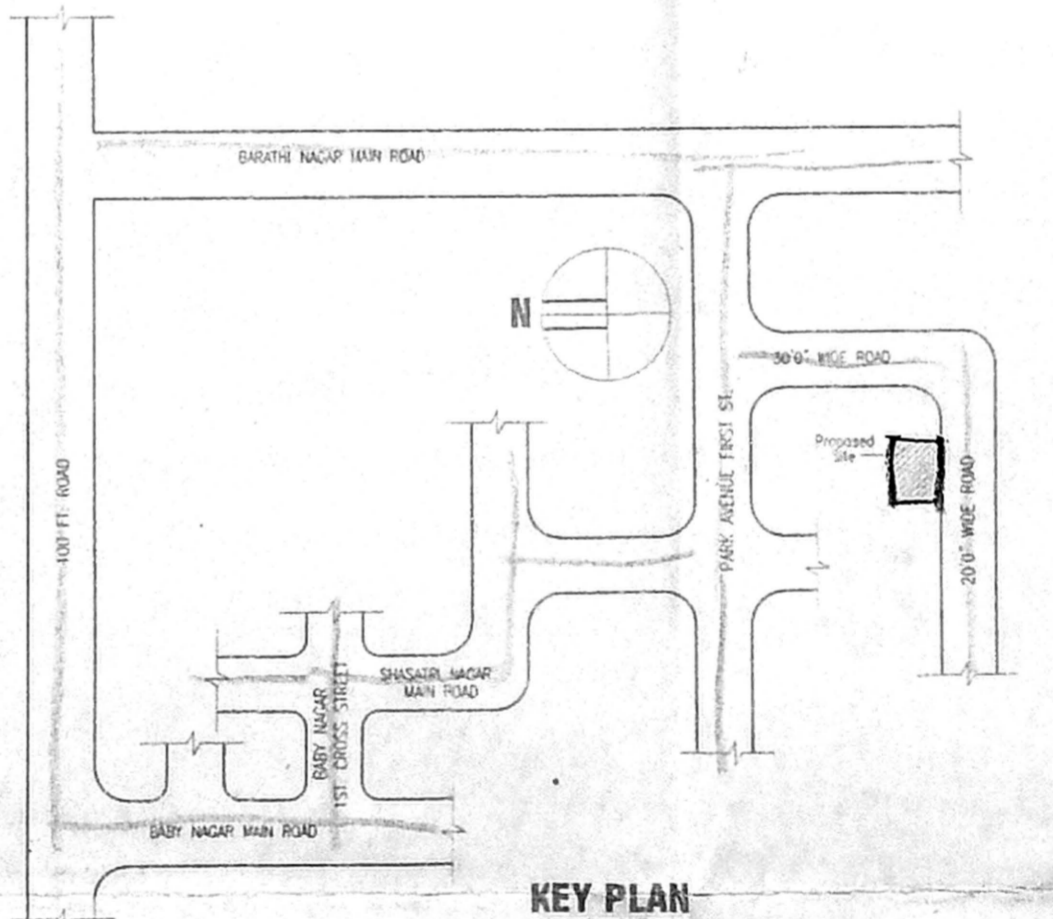
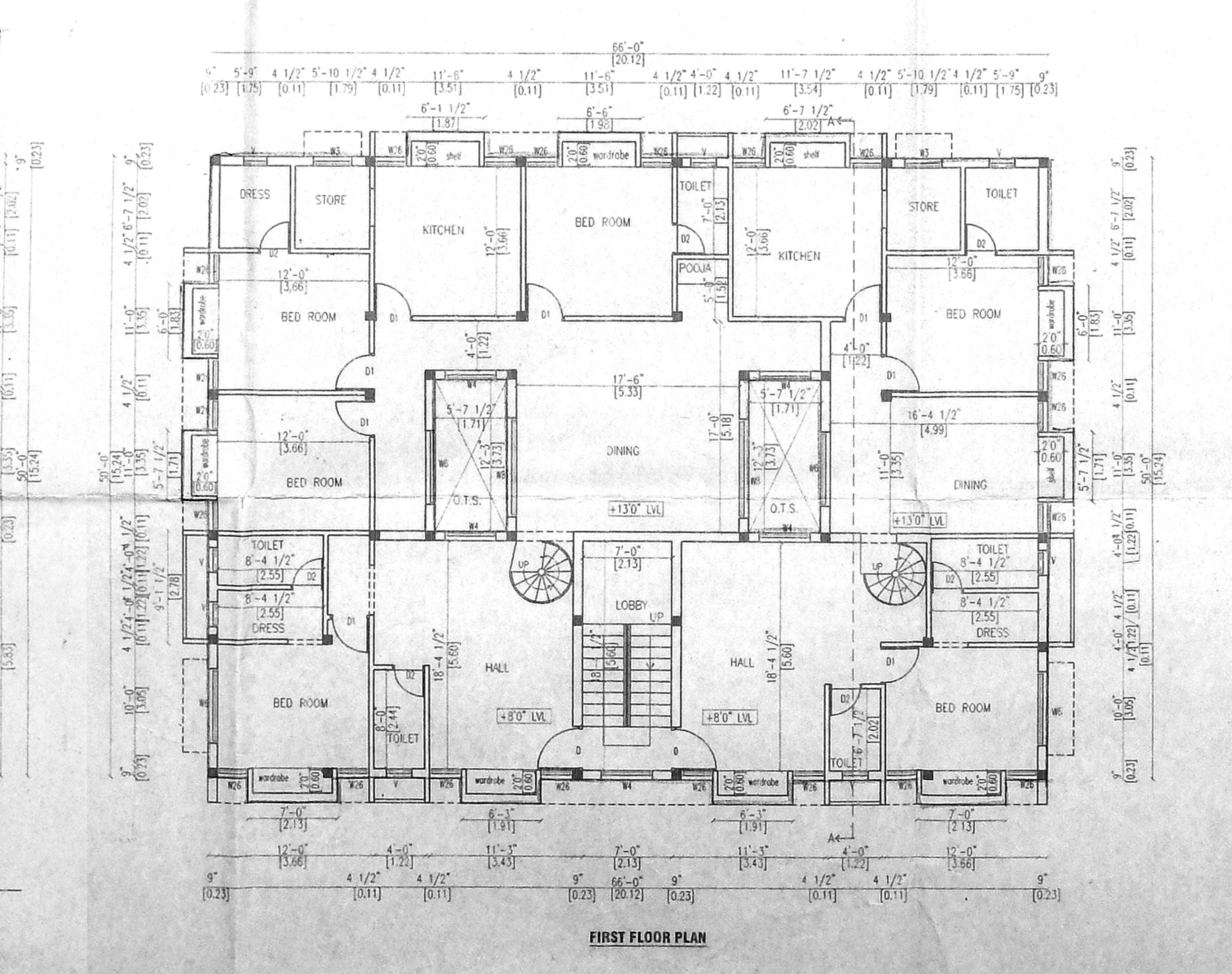
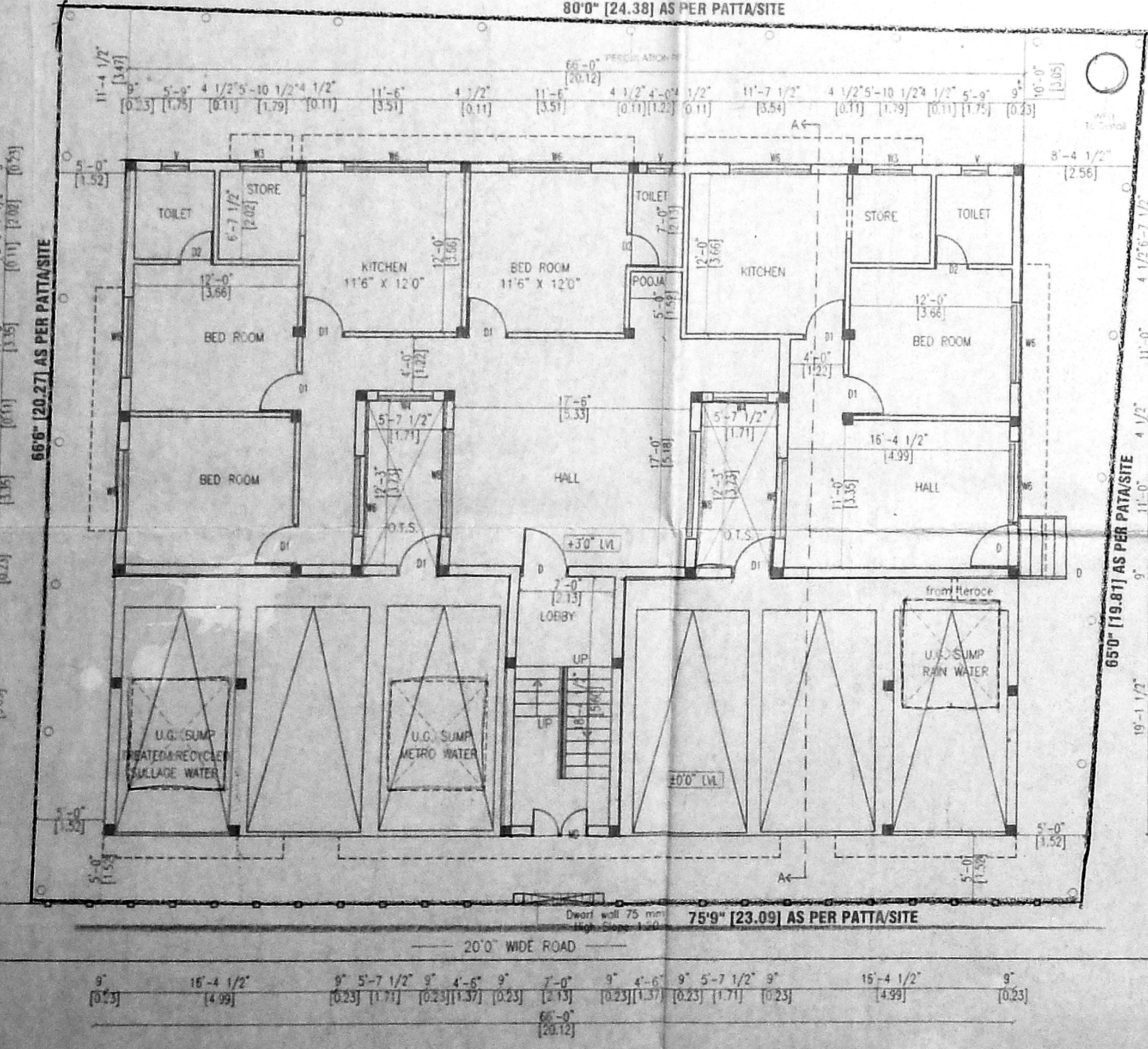
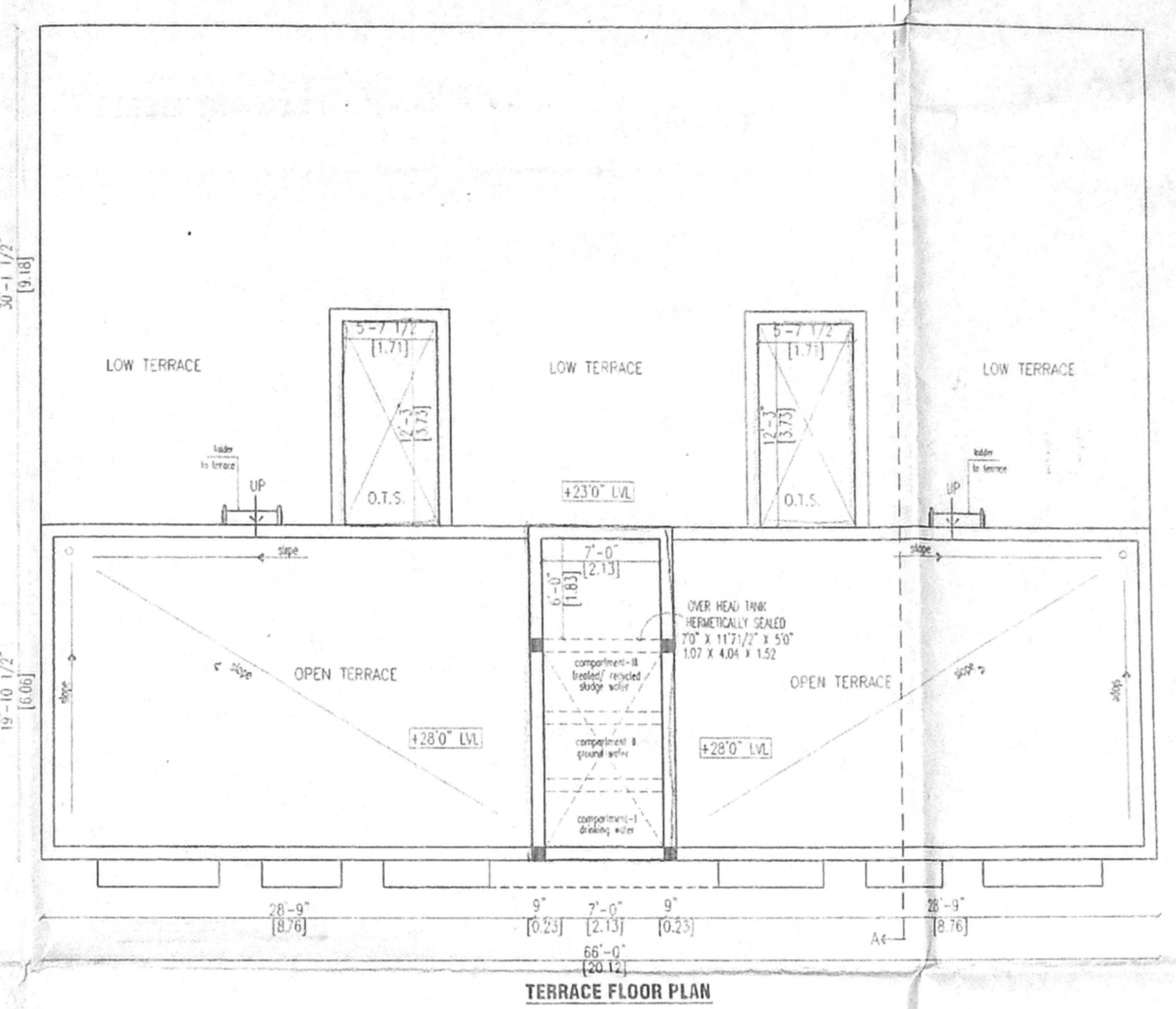
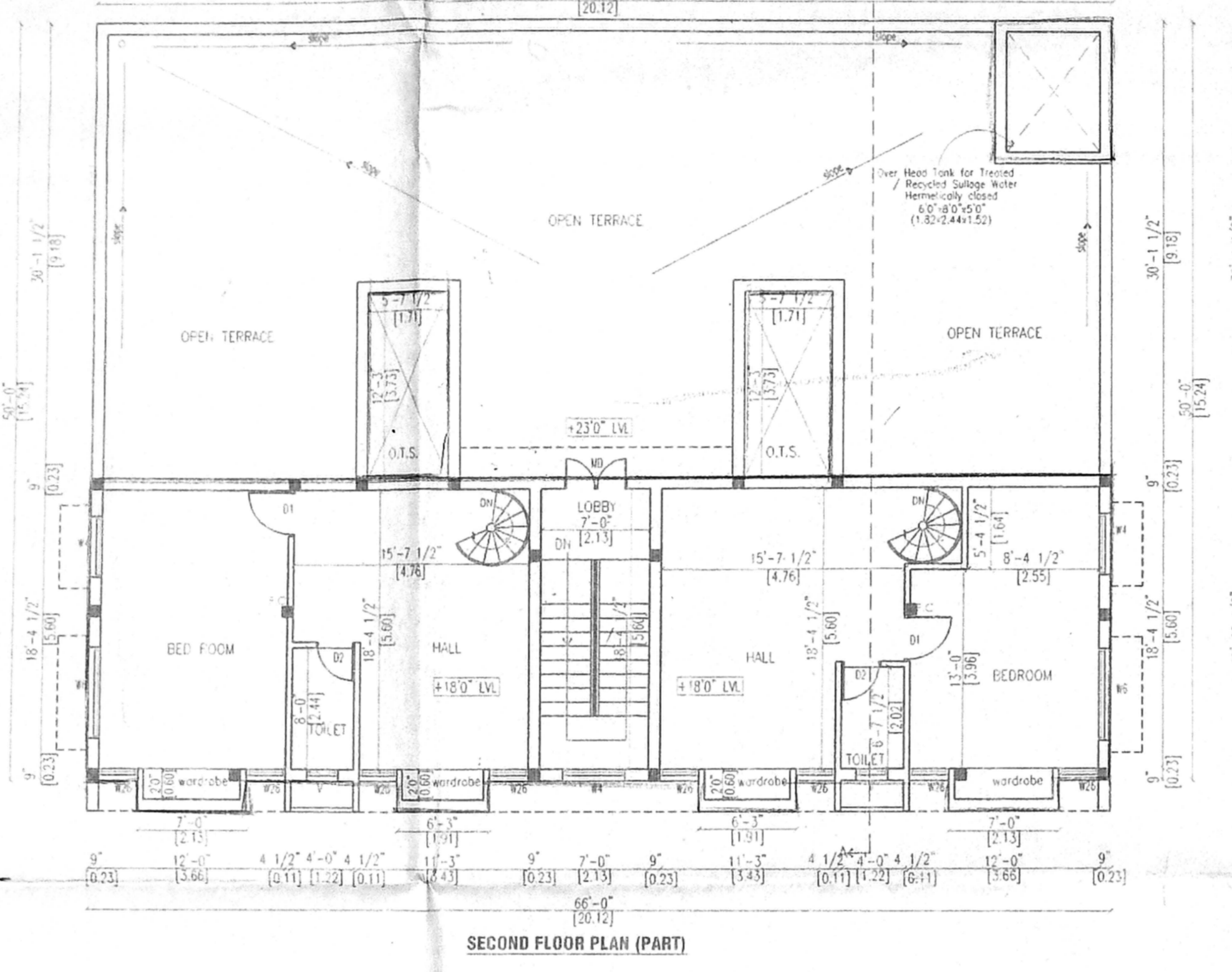
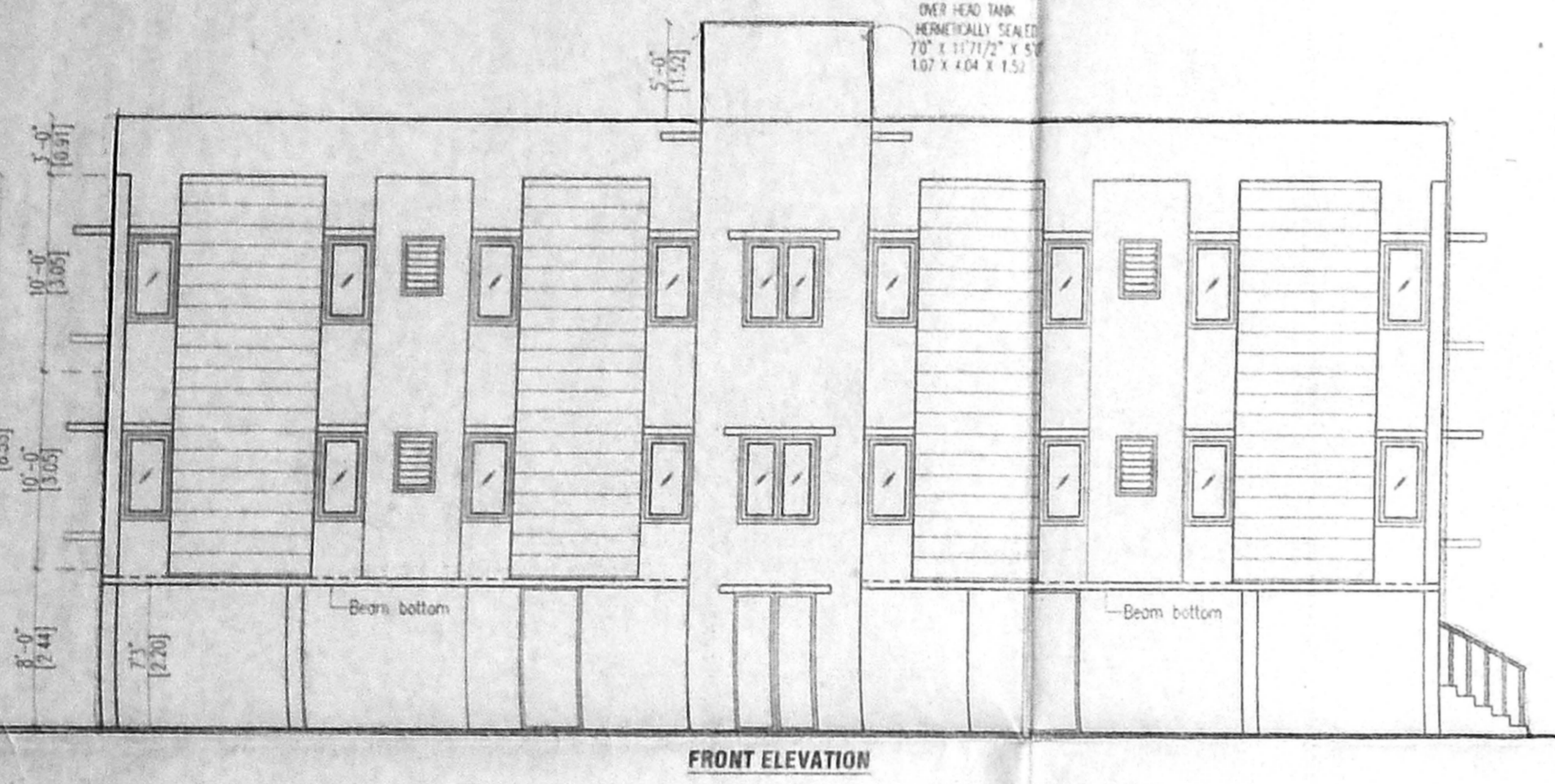

REFERENCE
 PROPOSED
 ROAD
 BOUNDARY
 SCALE
 NORTH POINT
 1" = 8'0"

OWNER(S)
[Signature]

LICENSED SURVEYOR
[Signature]

Palanivelu Deswanathan
 ARCHITECT AND INTERIOR DESIGNER
 CA. No. 1 CA/97/23319
 #9713 11, K.P. KOIL STREET,
 SAIGAPET, CHENNAI - 600 015.
 PHONE : 98410 13640

